

Code No: 152AH

JAWAHARLAL NEHRU TECHNOLOGICAL UNIVERSITY HYDERABAD

B. Tech I Year II Semester Examinations, September - 2023

ENGINEERING MECHANICS

(Common to CE, ME, MCT, MMT, AE, MIE, PTM)

Time: 3 Hours

Max. Marks: 75

Note: i) Question paper consists of Part A, Part B.

ii) Part A is compulsory, which carries 25 marks. In Part A, answer all questions.

iii) In Part B, Answer any one question from each unit. Each question carries 10 marks and may have a, b as sub questions.

**PART - A****(25 Marks)**

- 1.a) Define and explain the moment of force. [2]
- b) What is the couple? What is the arm of couple and its moment? [3]
- c) State the laws of static and dynamic friction. [2]
- d) How does centroid differ from centre of gravity? [3]
- e) State the parallel axis theorem. [2]
- f) What is inertia? [3]
- g) State the difference between kinematics of a particle and kinematics of a rigid body. [2]
- h) What is the difference between uniform acceleration and variable acceleration? [3]
- i) List the various types of motion. [2]
- j) Explain about motion on inclined smooth surfaces. [3]

**PART - B****(50 Marks)**

- 2.a) A simply supported beam of length 6 m carrying a uniformly distributed load of 5 kN/m over a length of 3 m from the right end. Calculate the reactions at both ends.
- b) Two identical rollers, each of weight  $W = 1000$  N, are supported by an inclined plane and a vertical wall as shown in figure 1 below. Find the reactions at the points of supports A, B and C. Assume all the surfaces to be smooth. [5+5]

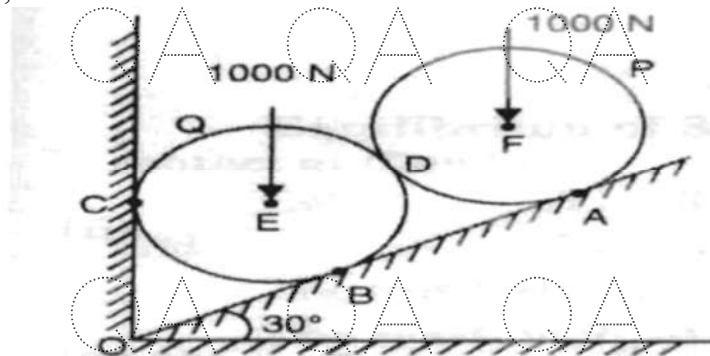

Figure 1  
OR

- 3.a) A simply supported beam of 3 m span carries two loads of 5 kN each at 1 m and 2 m from the left hand support. Find the reactions at both the ends.
- b) Two forces P and Q are acting at a point O as shown in figure 2 below. The resultant force is 400 N and angle  $\beta$  and  $\gamma$  are  $35^\circ$  and  $25^\circ$  respectively. Find the two forces P and Q. [5+5]

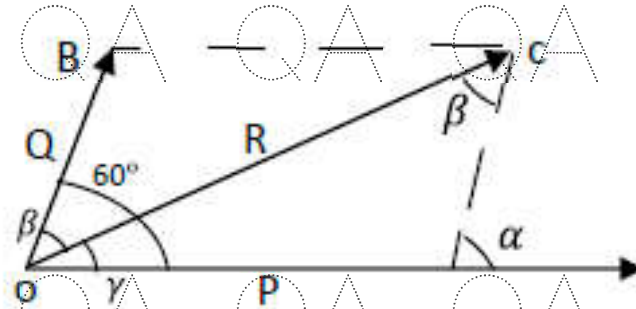

Figure 2

- 4.a) A pull of 20 N, inclined at 25 degrees to the horizontal plane, is required just to have a body placed on a rough horizontal plane. But the push required to move the body is 25 N. If the push is inclined at 25 degrees to the horizontal, find the weight of the body and co-efficient of friction.
- b) Find the centroid of an unequal angle section  $100 \text{ mm} \times 80 \text{ mm} \times 20 \text{ mm}$  shown in figure 3 below. [5+5]

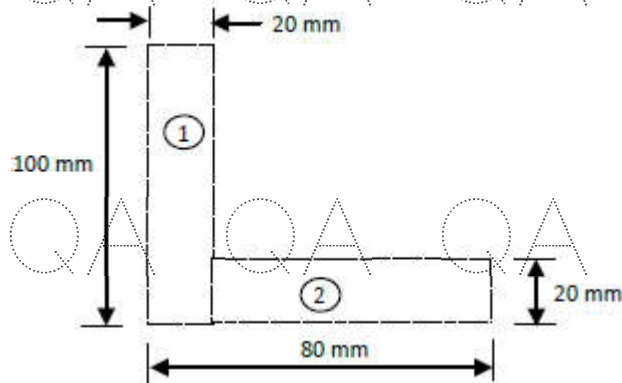

Figure 3  
OR

- 5.a) The efficiency of a screw jack is 55%, when a load of 1500 N is lifted by an effort applied at the end of a handle of length 50 cm. Determine the effort applied if the pitch of the screw thread is 1 cm.
- b) Derive the centre of gravity of quadrant of arc of a circle of radius R and circular sector of radius R and central angle  $\alpha$ . [5+5]

QA QA QA QA QA QA QA QA QA QA QA

- 6.a) Calculate the moment of inertia about horizontal and vertical axes ( $I_{xx}$  and  $I_{yy}$ ) of the section shown in figure 4 below.

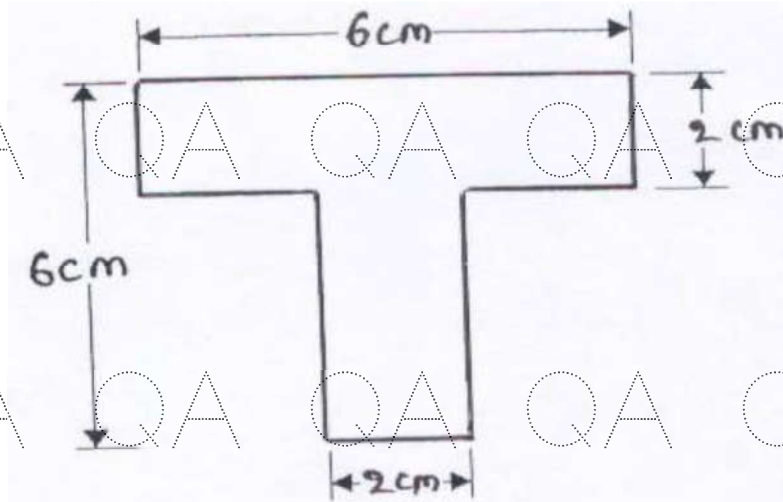

Figure 4

- b) Derive the expression for mass moment of inertia of a cylinder length ' $l$ ' radius ' $r$ ' and density ' $w$ ' about its longitudinal centroidal axis and about the centroidal transverse axis. [5+5]

OR

- 7.a) Find the moment of inertia of the area shown shaded in figure 5 given below, about the edge AB. [5+5]

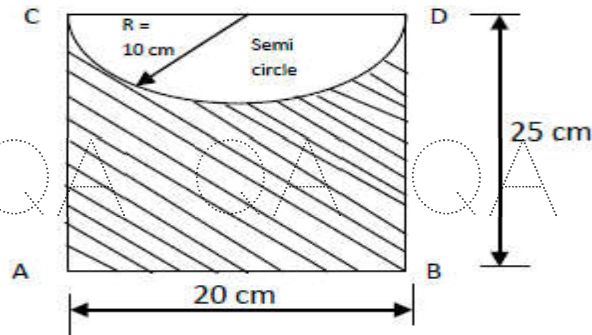

Figure 5

- b) Find the mass moment of inertia of a right circular cone of base radius ' $R$ ' and mass ' $M$ ' about the axis of the cone. [5+5]

- 8.a) A stone is dropped from the top of a tower 50 m high. At the same time, another stone is thrown upwards from the foot of the tower with a velocity of 25 m/s. When and where the two stones cross each other?

- b) The motion of a rotor is defined by the relation  $\theta = 8t^3 - 6(t-2)^2$ , where  $\theta$  and  $t$  are expressed in radians and seconds respectively. Determine: (i) When the angular acceleration is zero. (ii) The angular coordinate and angular velocity at that time. [5+5]

OR

- 9.a) A particle is constrained to move upward to the right along the path  $2y^2 = x^3 + 26$  where  $x$  and  $y$  are in cm. The  $x$  coordinate of the particle at any time is  $x = t^2 - t + 4$ . Determine the  $y$  components of velocity and acceleration at  $x = 600$  cm.

- b) A flywheel is rotating at 200 r.p.m and after 10 seconds it is rotating at 160 r.p.m. If the retardation is uniform, determine the number of revolutions made by the flywheel and the time taken by the flywheel before it comes to rest from the speed of 200 r.p.m. [5+5]

QA QA QA QA QA QA QA QA QA QA QA



10.a) A fighter plane is directly over an aircraft gun at time  $t = 0$  and an altitude of 1800 m. The plane is moving with a speed of 600 kmph. A shell is fired at a time  $t = 0$  in an attempt to hit the plane. If the muzzle velocity is 1000 m/sec, Find out the angle at which the gun should be held.

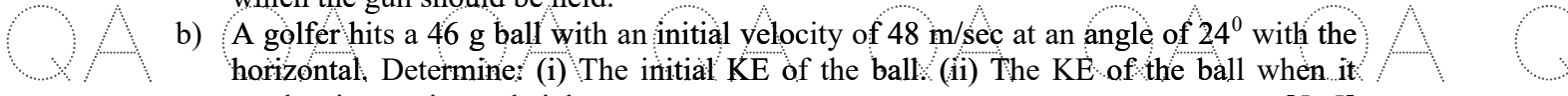

b) A golfer hits a 46 g ball with an initial velocity of 48 m/sec at an angle of  $24^\circ$  with the horizontal. Determine: (i) The initial KE of the ball. (ii) The KE of the ball when it reaches its maximum height. [5+5]

**OR**

11.a) Derive the expression of rotary motion by using D' Alembert's principle.

b) A homogeneous sphere of radius of  $a = 100$  mm and weight  $W = 10$  N Can rotate freely about a diameter. If it starts from rest and gains with constant angular acceleration, angular speed  $N = 180$  rpm, in 12 revolutions, find the action moment. [5+5]

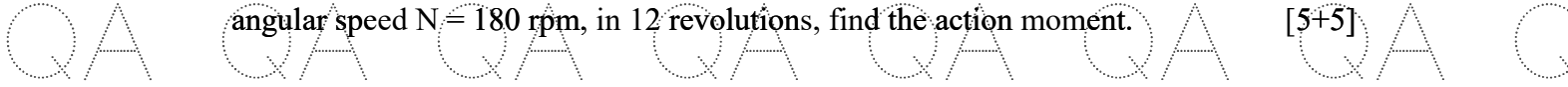

---ooOoo---

